

Teletector 6112M

Operating Manual for Models 6112M and 6112M/H



- Microprocessor controlled dose rate meter with telescope to measure gamma radiation and to detect beta radiation.
- Measuring quantity: Photon Dose Equivalent Rate \dot{H}_x (6112M) or Ambient Dose Equivalent Rate $\dot{H}^*(10)$ (6112M/H).
- Safety by distance: telescope extendible up to 4 m total length.
- Wide dose rate range from 0.1 $\mu\text{Sv/h}$ to 10 Sv/h, adjustable time constants.
- Storage of up to 450 measurements including location, dose rate, time, duration, and standard deviation of measurement.
- Serial transfer of current measurement and stored measurements to a PC. Easy processing of these data with standard Windows[®] software.
- Low power consumption (approx. 100 operating hours with four alkaline C cells).

Contents I

1. Function	1
2. Operation	2
2.1 Dose Rate Indication	2
2.2 Switching On	3
2.3 Switching Off	3
2.4 Adjusting LCD Contrast	3
3. The FUNCTION Menu and its Options	4
3.1 DOSE RATE	4
3.2 INFO	4
3.2.1 DR HISTORY	5
3.2.2 DOSE	5
3.2.3 STATISTICS	5
3.2.4 LOG	6
3.2.5 BATTERY CONDITION	6
3.3 RECORDING	7
3.3.1 RECORDING	8
3.3.2 MEASURING SCHEDULES	9
3.3.3 CLEAR RECORDING	9
3.4 THRESHOLDS	10
3.4.1 DR ALARM THRESHOLD	10
3.4.2 DOSE ALARM THRESH.	10
3.5 SERVICE	11
3.5.1 DATE / TIME	11
3.5.2 LANGUAGE	11
3.5.3 UNITS (6112M model only)	11
3.5.4 ILLUMINATION	12
3.5.5 TIME CONSTANT	12
3.5.6 CHECK DETECTORS	14
4. Status Line	14
5. SETUP Menu	15
5.1 Selecting OPERATION MODE	15
5.2 Setting DATE / TIME, DR ALARM THRESHOLD, and LANGUAGE	15
5.3 PARAMETERS	15
6. Operation Modes	16
6.1 6112M Mode	16
6.2 6150AD Mode	16
6.3 Fire Brigade Mode	18
7. Telescope	18

Contents II

8. Detecting Beta Radiation	19
9. Replacing the Batteries / Battery Warning	19
10. Serial Interface Connector	20
10.1 Pin Assignment	20
10.2 Serial Interface	20
10.3 Earphone Output	20
10.4 Power Supply	21
11. Energy Dependence and Directional Dependence	21
11.1 6112M	22
11.2 6112M/H	24
12. Radiological Check	26
13. Technical Data	28
13.1 Teletector 6112M	28
13.2 Earphone 865.1.4	30
13.3 Connecting Cable 865.1.3	30
13.4 Source Holder 761.14	31
13.5 Serial Interface	32

1. Function

The Teletector 6112M is a portable battery operated dose rate meter to measure photon radiation (gamma and X-radiation), and to detect beta radiation. Two GM counting tubes serve as detectors. The stainless steel telescope can be continuously extended up to more than four metres; its end carries the two tubes. The tubes are placed along the axis one behind the other; a groove marks the centre of each tube. The low range tube (end window tube ZP1400) can also detect beta radiation. Together with the high range tube (ZP1300) the Teletector covers a dose rate range from 0.1 $\mu\text{Sv/h}$ to 10 Sv/h, where it automatically switches between the two tubes.

The Teletector 6112M simultaneously measures dose rate, dose, dose rate mean value, standard deviation of mean value, and dose rate maximum value. A fully graphic liquid crystal display (LCD) with switchable illumination (LED back-light) shows all the information. Four keys allow to select functions from a menu, where the display always describes the current function of all keys. Menu options are represented in plain language. The user may select one of the three pre-programmed languages (German, English, French) or even a fourth individually programmable language. Besides the current function the display always shows some important parameters in a status line: battery condition, detector in use (low or high range), date, time, and whether alarm thresholds have been exceeded.

The loudspeaker allows single pulse detection and sounds when some alarm is on. In case of contamination, the speaker may easily be replaced without having to open the instrument.

A non-volatile memory stores all settings when switching the Teletector off or when replacing the batteries. The real time clock keeps date and time with the help of a rechargeable back-up battery. A 16-bit microprocessor controls all the functions.

The Teletector 6112M has three operation modes the user can select:

- 6112M mode This mode offers the widest scope of functions.
- 6150AD mode This mode makes operation very similar to operating a 6150AD5/6. Only the 6150AD5/6 functions will be available.
- fire brigade mode In this mode the Teletector only indicates dose rate, other functions are not available. The dose rate alarm threshold is fixed at 25 $\mu\text{Sv/h}$. This mode is particularly intended for use by fire brigades.

The two models 6112M and 6112M/H differ in the measuring quantity they are designed for. The Teletector 6112M measures any of these three quantities: Photon Dose Equivalent H_x (unit Sv), Exposure Dose J_s (unit R), and Air Kerma K_a (Absorbed Dose, unit Gy). Those three quantities are very close related to each other, because they can be converted to each other by simple conversion factors independent of photon energy:

$$\begin{aligned} J_s [\text{R}] &= 114 \text{ R/Gy} \cdot K_a [\text{Gy}] \\ H_x [\text{Sv}] &= 0.01 \text{ Sv/R} \cdot J_s [\text{R}] \\ H_x [\text{Sv}] &= 1.14 \text{ Sv/Gy} \cdot K_a [\text{Gy}] \end{aligned}$$

Because this conversion is independent of energy, the 6112M can allow the user to select one of the three units R, Gy, and Sv. H_x was the legal quantity in Germany from 1986 to 2001; however, the quantity H_x was hardly accepted internationally.

In 2001 we created the 6112M/H model for Ambient Dose Equivalent $H^*(10)$, which is also measured in Sv. This required modification of energy dependence, which means modification of energy compensation. The energy compensation is an alloy of heavy metals surrounding the counting tubes. The 6112M and 6112M/H models only differ in that energy compensation (and, of course, in their names and thus their labels). The 6112M/H also has a modified firmware (EPROM),

since a $H^*(10)$ model must no longer allow to switch the unit from Sv to R or Gy because this conversion is now energy dependent.

If you feel confused that the two models are designed for different quantities (H_x and $H^*(10)$), but use the same unit (Sv), keep in mind that a measuring *quantity* and its *unit* are different things. For example, think of an alternating current: it may be characterized by different quantities like peak value or root-mean-square value, which will have different values, although they are measured with the same unit (volts, amps). The same is true for a radiation field: you may measure its quantity as H_x or as $H^*(10)$, and you will get different results, although both are measured in Sv.

Operation and function do not depend on the measuring quantity. Therefore, from now on we shall distinguish between both models only if there are differences, for example when discussing energy dependence and directional dependence. Unless stated otherwise, all specifications apply to both models.

2. Operation

The easiest way to understand the basics of operation is to look at dose rate indication, see the following section.

2.1 Dose Rate Indication

Dose rate indication, which is the instrument's ground state, looks as follows:

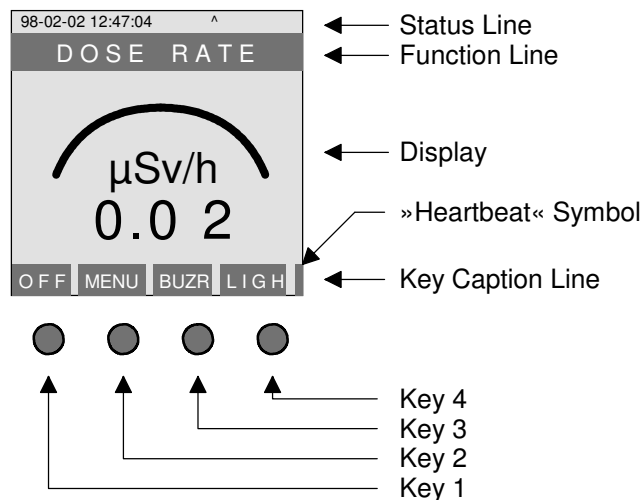

The status line is the same for all functions. It contains date, time, battery condition and currently active tube. It also indicates whether alarm thresholds have been exceeded. See chapter 4 for a detailed description of the status line.

The function line tells you the name of the currently active function.

The display area shows dose rate in both digital and analog representation (bar-graph covering two decades). The Teletector automatically selects range, unit, and prefix (μ , m, ...). Changing the range is emphasized by a short sound and two arrows on the left and the right of the digits. The arrows will point upwards, if a higher range was selected, and will point downwards, if a lower range was selected. This shall draw the user's attention to the fact that a new range was selected.

The meaning of the four keys depends on the function currently active. The key caption line explains the actions assigned to the keys. For space reasons, one key caption cannot have more than four characters. In dose rate mode the keys will produce the following actions:

- Key 1: OFF Switches the instrument off (after asking for confirmation).
- Key 2: MENU Calls the menu, see chapter 3.
- Key 3: BUZR Switches the speaker (buzzer) on and off. If dose rate alarm occurs, the speaker will automatically go on; the user may then switch it off again.
- Key 4: LIGH Switches the back-light on and off. This function is not available if back-light mode is set to »always on« (SERVICE menu). If back-light mode is »10s upon any key«, this key will switch the light on for 10s, just like any other key.

The »heartbeat« symbol is a small flashing bar indicating that the microprocessor operates correctly. So this flashing bar does not mean any warning, but, on the contrary, it tells you that the instrument »lives«.

2.2 Switching On

The »On« symbol ☉ on the housing below key 1 indicates that pressing this key switches the instrument on. Switching on is accompanied by a short sound as a check for the speaker. The Teletector displays manufacturer (Automess), release number, and serial number for about five seconds. During this period you may enter setup mode (see chapter SETUP Menu). After the five seconds have elapsed, the Teletector goes into its ground state, dose rate indication.

2.3 Switching Off

Pressing »OFF« (key 1) while in state »DOSE RATE« will switch the instrument off. To prevent you from inadvertently switching off, the instrument will first ask you for confirmation. You have to answer this question with »YES« (key 2) if you really want to switch off, or you may cancel this action by pressing key »ESC« or »NO«. If you do not respond within 10 seconds, the Teletector will return to the state »DOSE RATE«.

2.4 Adjusting LCD Contrast

You need to press two keys simultaneously to adjust contrast of the LC-Display:

- Increase contrast: Press and hold keys 2 and 3 simultaneously.
- Decrease contrast: Press and hold keys 2 and 4 simultaneously.

NOTE! You have to press and release both keys as simultaneously as possible (to be more precise: within 0.1 seconds), otherwise the keys' normal functions will be executed!

NOTE! Extreme contrast settings will produce a completely black or completely blank display which may appear like a fault!

3. The FUNCTION Menu and its Options

This chapter tells you how to call the functions from the »FUNCTION« menu. You get to this menu by pressing »MENU« (key 2) while in state »DOSE RATE«. The »FUNCTION« menu looks as follows:

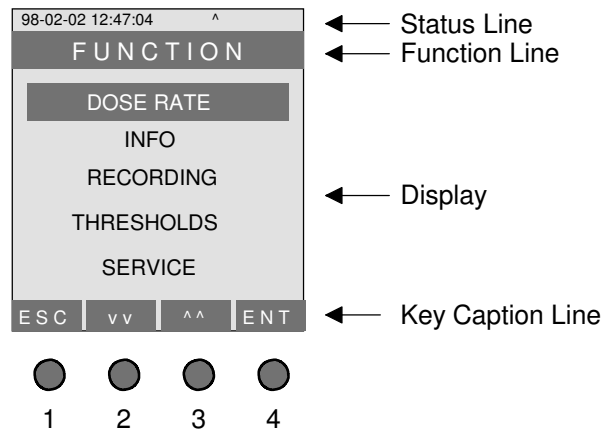

The five options in this menu are »DOSE RATE«, »INFO«, »RECORDING«, »THRESHOLDS«, and »SERVICE«. The selected option is highlighted by a scroll bar. Move the bar with keys 2 and 3 to the desired function and execute that function by pressing »ENT« (key 4). »ESC« (key 1) will leave the FUNCTION menu, which means you will return to dose rate indication.

The captions »ESC« for key 1 and »ENT« for key 4 were chosen according to computer keyboards, where »Escape« means leaving the current function, and »Enter« confirms or terminates input.

Executing the first function (»DOSE RATE«) leads back to dose rate indication (and therefore has the same effect as pressing the »ESC« key). The other four functions call their own sub-menus. Throughout these sub-menus and other functions, the »ESC« and »ENT« keys will work in the same manner, which means that »ESC« will return to the previous menu level, and »ENT« will execute the selected menu option.

The following sections describe the five functions in detail.

3.1 DOSE RATE

This function indicates the current dose rate; it is the instrument's ground state. Indication of dose rate was already described in section 2.1, see there.

3.2 INFO

This function supplies further information through a sub-menu containing the options described below.

3.2.1 DR HISTORY

This function graphically represents dose rate history, where »history« means the progress of dose rate in the past.

After having been switched on, the Teletector averages dose rate at one-minute intervals (independent of current dose rate indication) and stores those one-minute averages in a circular buffer. The circular buffer will overflow after 48 hours, then the most recent value will replace the oldest one. Therefore you may review dose rate history for up to the last 48 hours. Graphic dose rate indication always comprises two decades that are automatically scaled according to the highest dose rate in the currently visible time window.

- Key assignment within function DR HISTORY:
 - Key 1: ESC Returns to the function menu.
 - Key 2: <- Shifts time window one hour to the left.
 - Key 3: -> Shifts time window one hour to the right.
 - Key 4: LIGH Switches the back-light.

3.2.2 DOSE

This function displays the dose that has been accumulated since the instrument was switched on or since the dose was reset to zero. It also indicates date and time when dose accumulation started, and the duration of dose accumulation. Note that dose is always accumulated in the background, that is even if the function DOSE is not currently selected.

If a dose alarm threshold is active, the instrument will not display the duration of dose accumulation, but the time that will elapse until the dose gets to the threshold. Also, a bar-graph acting as a gauge indicates the dose value in relation to the threshold (0%-100%).

- Key assignment within function DOSE:
 - Key 1: ESC Returns to the function menu.
 - Key 2: CLR Calls a function to clear (delete) the dose. After having asked for your confirmation, the Teletector will reset dose and duration of dose accumulation to zero. If you do not respond within 10 seconds, the Teletector will return to dose indication without modifying any data.
 - Key 3: BUZR Switches the speaker (buzzer) on and off in case of dose alarm.
 - Key 4: LIGH Switches the back-light.

3.2.3 STATISTICS

This function displays statistical information that has been collected since the instrument was switched on or since the statistics were reset to zero:

- dose rate mean value,
- standard deviation of mean value,
- dose rate maximum value,
- starting time and duration of measurement.

The mean value allows to measure low dose rates ($< 1\mu\text{Sv/h}$) quite accurately, where the standard deviation tells you the statistical accuracy. Note that statistics are always collected in the background, that is even if the function STATISTICS is not currently selected.

NOTE! The dose rate mean value is only suitable for measuring radiation fields that are constant in time and space!

- Key assignment within function STATISTICS:
 - Key 1: ESC Returns to the function menu.
 - Key 2: CLR Calls a function to clear (delete) the statistics. After having asked for your confirmation, the Teletector will reset mean value, standard deviation, maximum value, and duration to zero. If you do not respond within 10 seconds, the Teletector will return to indication of statistics without modifying them.
 - Key 3: No function.
 - Key 4: LIGH Switches the back-light.

3.2.4 LOG

This function allows to view the logbook. The logbook may enable you to review exceptional events having occurred during previous uses of the instrument.

When switching itself off, the Teletector stores the following data in his logbook:

- starting time (date and time when switched on),
- duration of use,
- dose rate mean value for that use,
- dose rate maximum value for that use,
- dose accumulated during that use.

These values are independent values; they will not be affected when deleting dose or statistics. You may only view previous uses, not the current one, because the current one is not yet terminated.

The Teletector stores data of the last 15 uses. If memory is filled, the most recent recording will replace the oldest one. When viewing the log, you may move from one recording to the other with the up and down keys.

To prevent less important recordings from replacing more important ones, only such uses will be stored, where

- the duration of use was longer than five minutes, *or*
- the dose rate mean value during that use was higher than $1\mu\text{Sv/h}$, *or*
- the dose rate maximum value during that use was higher than $10\mu\text{Sv/h}$.

3.2.5 BATTERY CONDITION

This function gives information about the battery condition. It displays battery voltage digitally and residual battery capacity as a percentage gauge. If voltage drops below 4 volts, the Teletector issues battery warning in all functions, consisting of a short sound and the function line alternating between its normal text and the text »BATTERY CONDITION«.

In this case you should replace the batteries as soon as possible.

3.3 RECORDING

This sub-menu contains all options required for recording dose rate measurements. The Teletector 6112M can store up to 450 measurements. One measurement is not just a shot of the current dose rate, but it is an averaged value of dose rate, where the user can control the averaging time. This permits improved statistical accuracy of the stored measurements especially at low dose rates.

As a factory default, the individual measurements, also called »places« or »items«, are named by their numbers 1 through 450. They are divided into groups called »measuring schedules« to make selection of a particular place easier and to make logical groups available. The factory default offers the schedule »All items« and 16 standard schedules »Progr. x« as follows:

<u>Name of measuring schedule:</u>	<u>Comprises these places:</u>
All items	1 - 450
Progr. 1	1 - 50
Progr. 2	51 - 100
Progr. 3	101 - 150
Progr. 4	151 - 200
Progr. 5	201 - 250
Progr. 6	251 - 300
Progr. 7	301 - 350
Progr. 8	351 - 400
Progr. 9	401 - 450
Progr. 10	1 - 100
Progr. 11	101 - 200
Progr. 12	201 - 300
Progr. 13	301 - 400
Progr. 14	1 - 225
Progr. 15	226 - 450
Progr. 16	1 - 450

Once a schedule has been selected, only places of that schedule are available for storage. Once the place has been selected, the user can start the measurement. The Teletector will then average dose rate until the user either cancels (rejects) or terminates (stores) the measurement by pressing the corresponding key.

Any Teletector 6112M can perform the recording just described without needing additional accessories. Recording is even more comfortable with the help of a computer and suitable software: you may give the places real names and divide them into your own measuring schedules.

Furthermore, you can assign one of the three following recording modes to each of the places:

- Duration: the measurement will be stored automatically after a given period of time has gone by.
- Standard deviation: the measurement will be stored automatically after the standard deviation has gone below a given limit.
- MAX: at first the Teletector displays current dose rate to guide the user (for example to find the maximum value inside a room). As soon as the user has pressed the start key, the measurement will start. Recording will not end automatically. The user has to either cancel (reject) or terminate (store) the measurement by pressing the corresponding key.

Customized place names and measuring schedules are particularly useful for routine measuring tasks in a nuclear facility.

3.3.1 RECORDING

Calling this function displays the list with the places. You may view places already measured, or you may decide to measure some particular place. The selected place is highlighted by a scroll bar. Move the bar with the up key (^) or the down key (v) to the desired place (keep the key depressed to move faster). Only the places of the current schedule are available.

Data for each place comprise two lines. The content of these two lines depends on whether you use factory default places or customized places:

- Factory default places:

- Line 1 contains place number.
- Line 2 contains value (dose rate) and duration of the measurement. A free place (a place not measured so far) is represented as:

---- $\mu\text{Sv/h}$ 0s

The scheduled duration of 0s means a permanent measurement until the user presses a key. A place already measured displays value and duration.

- Customized places:

- Line 1 contains place name.
- Line 2 contains value (dose rate) and, depending on recording mode, duration or standard deviation of the measurement. A free place is represented as:

---- $\mu\text{Sv/h}$ xxx

»xxx« stands for the recording mode of that place: scheduled duration (in seconds), or scheduled standard deviation (in %), or »MAX«. A place already measured displays value and, depending on recording mode, duration or standard deviation. Places recorded in »MAX« mode always display duration.

Once you have selected a place, press »ENT« to start the measurement. The function line now reads »RECORDING ...«. The display shows:

- place (number or name),
- scheduled and actual value of duration (or standard deviation),
- dose rate mean value.

The following applies to all cases: a scheduled duration of 0s means a permanent measurement until you press a key. You may cancel (reject) any measurement by pressing »ESC«, and you may terminate (store) any measurement by pressing »END«. When terminating the measurement of a customized place with »END«, the value will be stored before it has reached its target condition (duration or standard deviation). You cannot erase a place's measurement, you can only replace it by a new measurement.

NOTE!

If you select a place already carrying a measurement, the new measurement will replace the existing one, unless you cancel the new measurement by »ESC«!

- Key assignment within function RECORDING:
 - Key 1: ESC Returns to the function menu.
 - Key 2: vv Selects next place.
 - Key 3: ^^ Selects previous place.
 - Key 4: ENT Starts measurement.
- Key assignment within function RECORDING ...:
(only in MAX recording mode directly after start of measurement):
 - Key 1: ESC Cancels measurement, returns to place selection.
 - Key 2: No function.
 - Key 3: STAR Starts measurement, key caption changes from STAR to END.
 - Key 4: LIGH Switches the back-light.
- Key assignment within function RECORDING ...:
 - Key 1: ESC Cancels measurement, returns to place selection.
 - Key 2: No function.
 - Key 3: END Ends and stores measurement, returns to place selection.
 - Key 4: LIGH Switches the back-light.

3.3.2 MEASURING SCHEDULES

This option allows to select »All items« or one of the 16 measuring schedules. Use the up key (^) or the down key (v) to move to the desired schedule which is described by its name and the numbers of its first and last place. Press »ENT« to select that schedule, or press »ESC« to return to the RECORDING menu.

You need a PC and suitable software to create your own measuring schedules and feed them into the Teletector.

3.3.3 CLEAR RECORDING

This option clears all of the recordings including their values, customized names and schedules.

NOTE! This function does not only clear all of the measurements, but also their names and parameters. It resets places and schedules to factory default!

3.4 THRESHOLDS

This function allows to view and adjust the alarm thresholds for dose and dose rate.

3.4.1 DR ALARM THRESHOLD

This function allows to view and adjust the dose rate alarm threshold. This threshold works as follows: if dose rate reaches or exceeds the threshold, the Teletector automatically switches to dose rate indication and issues a rapidly intermittent sound as an acoustic warning. As a visual warning, the left half of the status line alternates between its normal indication and the text »RATE ALARM«. You may switch off the acoustic alarm with the key »BUZR«. As soon as dose rate drops below the threshold, the alarm will automatically go out. If a new alarm appears, both visual and acoustic alarm will go on again. In case dose rate alarm and dose alarm occur simultaneously, dose rate alarm has priority.

NOTE! Dose rate warning is not active in modes RECORDING and CHECK DETECTORS!

NOTE! Dose rate alarm thresholds close to natural background (< 0.2 µSv/h) can make the warning go on and out frequently and therefore can make the Teletector difficult to operate! (In such a case you may re-adjust the threshold via the SETUP menu).

This function displays the current alarm threshold. If you want to modify its value, simply change the digits with the increment key (++) or the decrement key (--). A small bar underlining the digit serves as a cursor and marks the digit to be modified. Move the cursor to the right with the right arrow key (->). From the rightmost digit the cursor will move around to the leftmost digit, so you may move to any digit, although there is no left arrow key. You can set the threshold to any value in the range of 0.01 µSv/h to 9.999 999 99 Sv/h. Setting the threshold to 0 (zero) disables dose rate warning.

- Key assignment within function DR ALARM THRESHOLD:
 - Key 1: ESC Returns to THRESHOLDS, accepts dose rate alarm threshold.
 - Key 2: -> Moves cursor to the right.
 - Key 3: ++ Increments the digit above the cursor.
 - Key 4: -- Decrements the digit above the cursor.

3.4.2 DOSE ALARM THRESH.

This function allows to view and adjust the dose alarm threshold. This threshold works as follows: if dose reaches or exceeds the threshold, the Teletector automatically switches to dose indication and issues a slowly intermittent sound as an acoustic warning. As a visual warning, the right half of the status line alternates between its normal indication and the text »DOSE ALARM«. You may switch off the acoustic alarm with the key »BUZR«.

NOTE! Once you have acknowledged the dose alarm, there will be no further dose alarm!

NOTE! Dose warning is not active in modes RECORDING and CHECK DETECTORS!

This function displays the current alarm threshold. If you want to modify its value, simply change the digits with the increment key (++) or the decrement key (--). A small bar underlining the digit

servers as a cursor and marks the digit to be modified. Move the cursor to the right with the right arrow key (->). From the rightmost digit the cursor will move around to the leftmost digit, so you may move to any digit, although there is no left arrow key. You can set the threshold to any value in the range of 0.01 μSv to 9.999 999 99 Sv. Setting the threshold to 0 (zero) disables dose warning.

- Key assignment within function DOSE ALARM THRESH.:
 - Key 1: ESC Returns to THRESHOLDS, accepts dose alarm threshold.
 - Key 2: -> Moves cursor to the right.
 - Key 3: ++ Increments the digit above the cursor.
 - Key 4: -- Decrements the digit above the cursor.

3.5 SERVICE

This sub-menu contains options to set various parameters. It also allows to check the detectors with a check source.

3.5.1 DATE / TIME

You can set the Teletector's internal real time clock with this function. Use the scroll bar to select between minutes, hours, day, month, and year. Use the down key (vv) to move the bar downwards, where the bar will move from the bottom line back to the top line. If necessary, increment or decrement the selected value with the corresponding keys. When you exit the function, and if you modified at least one of the values, the new date and time will be transferred to the Teletector's clock, and seconds will be set to zero. If you did not make any changes, the clock will not be touched.

NOTE! Setting date and time will not modify either starting time or duration of DOSE accumulation and STATISTICS!

3.5.2 LANGUAGE

This function selects one of four languages. After calling the function the scroll bar automatically points to the currently selected language. Use up and down keys to move the bar. The Teletector immediately changes the language as you move through the languages. You may choose one of the three pre-set languages »Deutsch« (German), »English«, or »Français« (French). With a PC and suitable software you can define a fourth language, load it into the Teletector and select it.

3.5.3 UNITS (6112M model only)

The 6112M/H model does not provide this function because ambient dose equivalent $H^*(10)$ cannot be converted to another quantity independent of photon energy.

With the 6112M model, this function allows to select as unit either Sievert (H_x), Roentgen, or Gray, where the following conversion is assumed for all photon energies:

$$114 \text{ R} = 1.14 \text{ Sv} = 1 \text{ Gy}$$

Changing the unit only affects display. Internally the 6112M model always uses Sievert (H_x). This also applies to recorded values and all values that can be transmitted through the serial interface.

3.5.4 ILLUMINATION

This function selects how the LCD illumination (LED back-light) works. After calling the function the scroll bar automatically points to the currently selected mode.

There are three options:

- »On/Off by LIGH key«
Pressing the »LIGH« key toggles the back-light on and off. The advantage of this mode is that the illumination can be switched on permanently if necessary. At the same time, this may be a disadvantage: if you switched on the illumination unintentionally, and you do not realize this because of bright ambient conditions, you will waste batteries. Also, before selecting this mode, consider that for space reasons the »LIGH« key is not available in all functions.
- »10s on by any key«
Pressing any key (including the »LIGH« key itself) switches the back-light on. After 10 seconds the back-light will automatically go out again. This avoids wasting batteries by unintentional illumination. However, in dark ambient conditions, you have to switch the back-light on repeatedly.
- »Always on«
The back-light is always on. The user does not need to care about illumination. However, the price for this ease is higher battery consumption.

The illumination consumes quite much battery power, so try to use it only when necessary. The Teletector assists you in saving energy: if battery voltage drops below 4.5 volts, it operates illumination at approximately half power. Below 4.0 volts it switches illumination completely off. In this case you should replace the batteries anyway.

3.5.5 TIME CONSTANT

This function selects the time constant. The time constant always floats with dose rate. You may select the time constant to float within one of these three ranges: 16s to 2s, 8s to 2s, or 4s to 2s. The smaller the time constant, the faster the Teletector responds to changes in dose rate. Note, however, that faster response means greater standard deviation (stronger fluctuations) of dose rate indication.

The time constant is larger at low dose rates and becomes smaller as dose rate increases. Time constant and standard deviation are linked to each other and depend on dose rate. The diagrams on the next page show this dependence.

If you require measurements with even lower standard deviation (better statistical accuracy), use dose rate mean value (menu option INFO / STATISTICS).

Time constant floating from 16s to 2s:

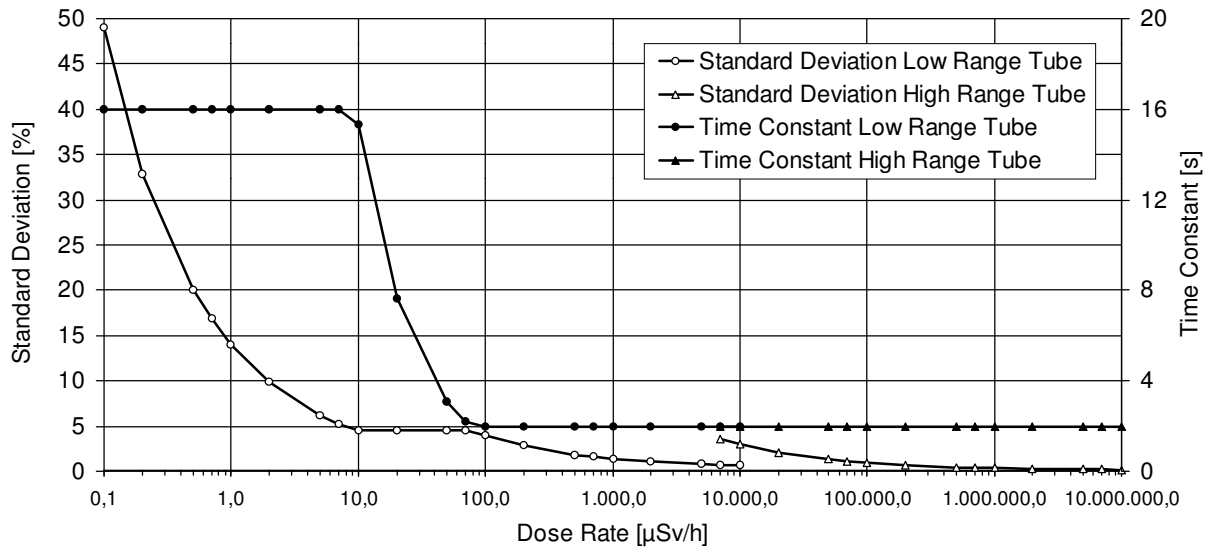

Time constant floating from 8s to 2s:

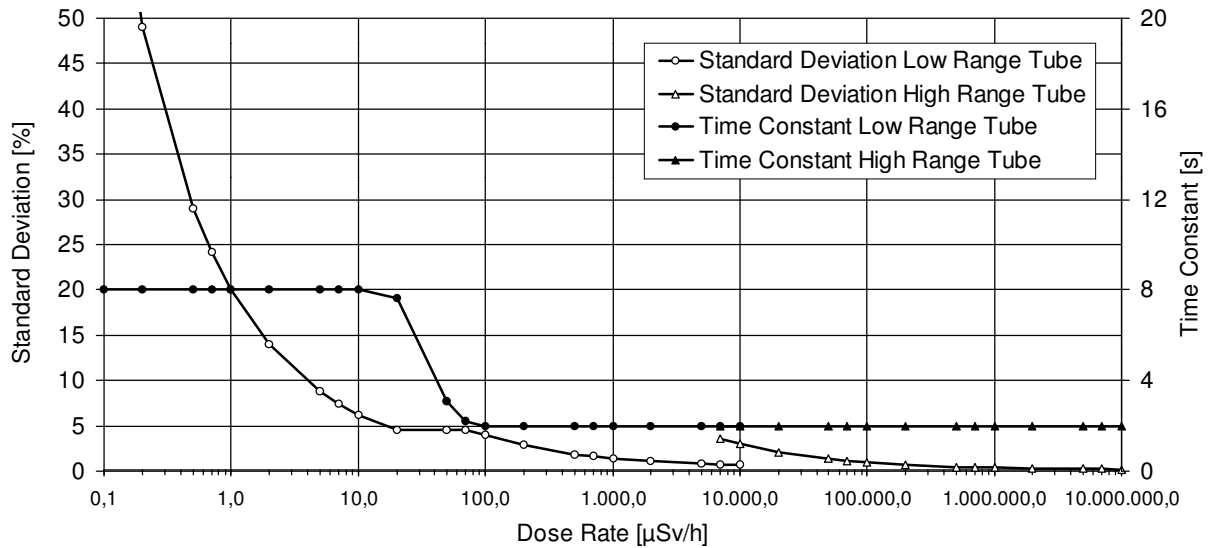

Time constant floating from 4s to 2s:

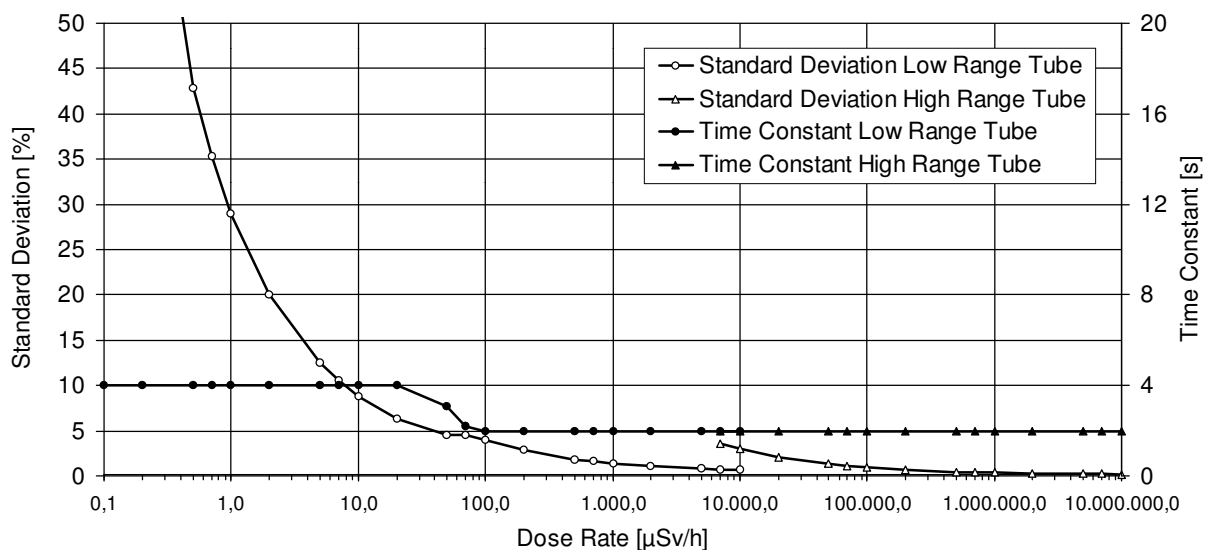

3.5.6 CHECK DETECTORS

This function allows to check the two GM tubes with the help of a check source. Select the low or high range tube with the scroll bar and the up/down key (»^v«). Expose the selected tube to the check source. Press »STAR« to start the measurement. The key caption changes to »STOP« indicating that pressing this key again will stop the measurement. During the measurement the Teletector displays dose rate mean value and number of pulses counted so far. As soon as the Teletector has counted 10 000 pulses, which correspond to a standard deviation of 1%, it stops the measurement. You may earlier stop the measurement by pressing »STOP«, which will result in poorer statistical accuracy (standard deviation greater than 1%), or you may cancel the measurement at any time with the »ESC« key.

NOTE! **Dose warning and dose rate warning are not active while using this function!**

4. Status Line

The status line is the topmost line in the display. It contains date, time, and current operation conditions. It also indicates whether an alarm threshold is exceeded.

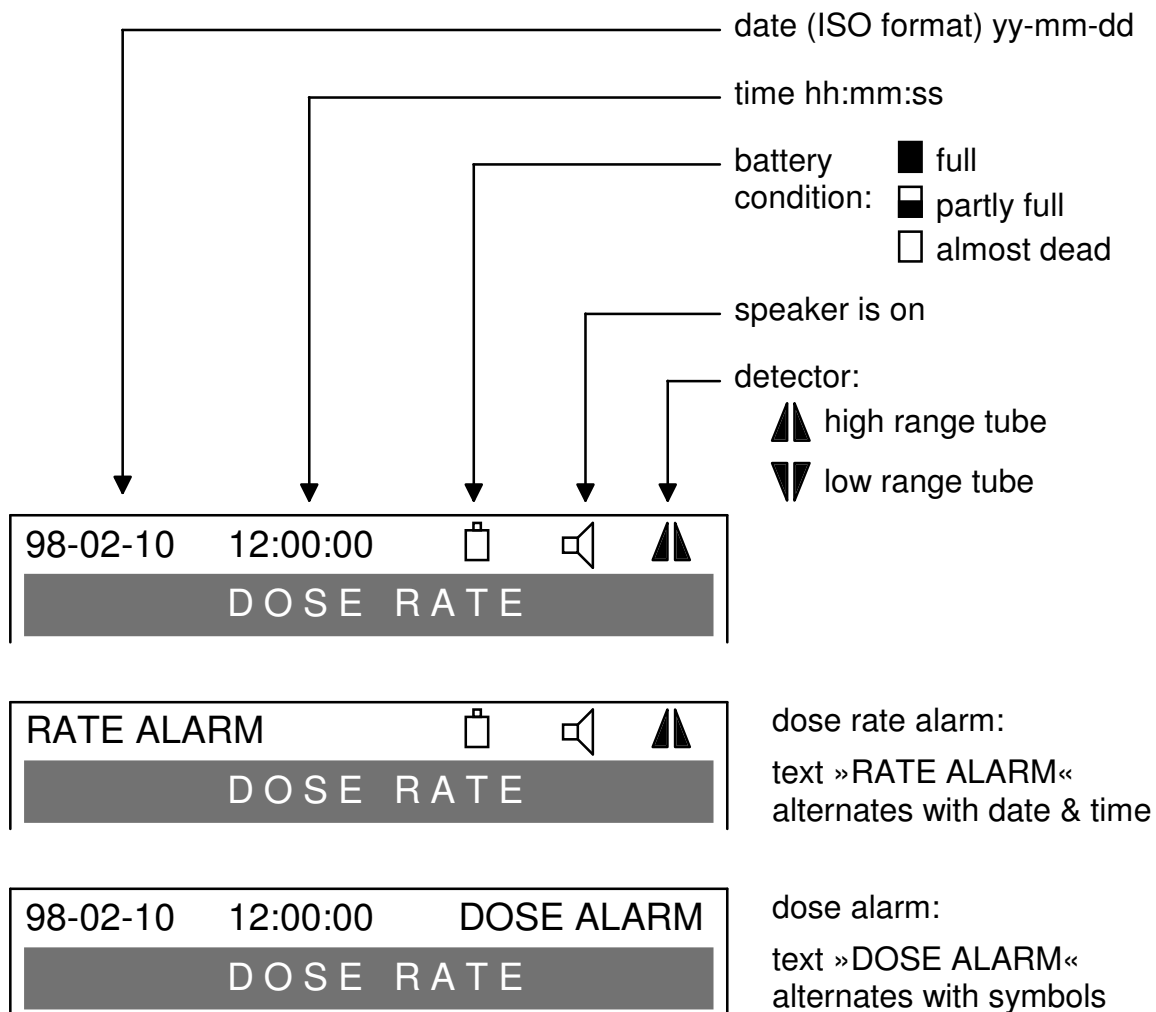

5. SETUP Menu

After having been switched on, the Teletector displays release numbers of hardware and software and its serial number for some seconds. During this time you can call the SETUP menu by pressing key 4 (the rightmost key). The SETUP menu allows to set operation mode, date & time, dose rate alarm threshold, and language. Select an option in the same way you did in the other menus. Pressing »ESC« leaves the SETUP menu and returns to the Teletector's ground state, dose rate indication.

5.1 Selecting OPERATION MODE

This sub-menu contains the three operation modes. It is the only menu always presenting its options in German independent of LANGUAGE setting:

- 6112M-Mode:
This mode offers the widest scope of functions, that is all the functions described so far.
- Feuerwehrmode (= fire brigade mode):
In this mode the Teletector only indicates dose rate, other functions are not available. The only threshold is a dose rate alarm threshold fixed at 25µSv/h. Keys 1 through 4 have the functions: ON/OFF, no function, SPEAKER, ILLUMINATION. This mode is particularly intended for users not very familiar with radiation meters.
- 6150AD-Mode:
This mode makes operation very similar to operating a 6150AD. Consequently, keys 1 through 4 have the functions: ON/OFF, FUNCTION, SPEAKER, ILLUMINATION. This mode is particularly intended for users who are familiar with the dose rate meter 6150AD and would like to use only the 6150AD's functions.

The Teletector will keep its operation mode when being switched off. The only way to set operation mode is via the SETUP menu.

Chapter 6 describes operation modes in more detail.

5.2 Setting DATE / TIME, DR ALARM THRESHOLD, and LANGUAGE

These SETUP options call the same functions as described earlier in the SERVICE and THRESHOLDS menus. However, now these functions cannot be interrupted by a dose or dose rate alarm, because they were called from the SETUP menu.

5.3 PARAMETERS

This option displays calibration parameters for service purposes only.

6. Operation Modes

This chapter describes the operation modes in more detail.

NOTE! Setting of time constant and with it standard deviation applies to all operation modes, although setting is only possible in 6112M mode (SERVICE menu)!

6.1 6112M Mode

This mode comprises all the functions described so far.

6.2 6150AD Mode

This mode makes display and operation very similar to a dose rate meter 6150AD, particularly to a 6150AD5 or 6150AD6 with a telescopic probe 6150AD-t. The first display after switching the Teletector on is dose rate indication:

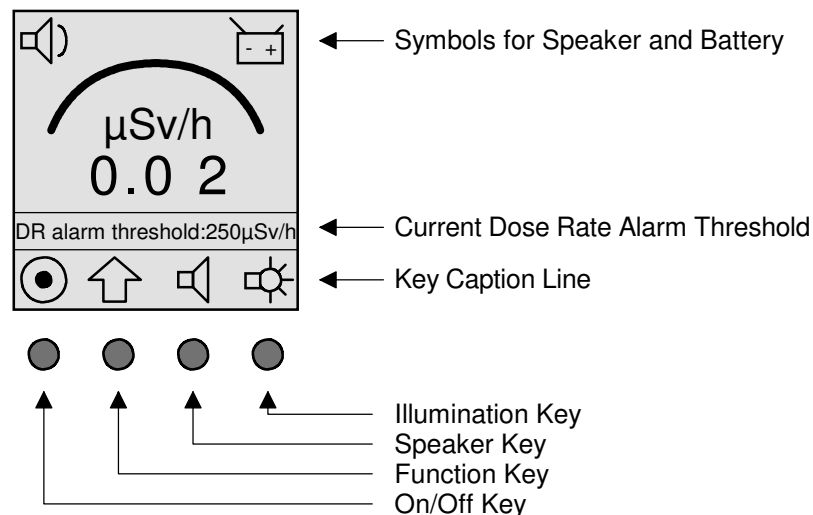

The speaker symbol indicates whether acoustic single pulse detection is on. A flashing speaker symbol indicates dose rate alarm.

The battery symbol serves for battery warning: it flashes if battery voltage drops below 4 volts. Pressing the speaker key will turn off the continuous sound belonging to battery warning. After that the battery symbol is continuously on. This applies to all indications, not only to dose rate indication.

- **On/Off Key:**
This key switches the instrument on and off. Switching off is only possible while the instrument indicates dose rate. Furthermore, this key serves to clear various values that can be called with the function key (see explanation of function key below). Pressing the on/off key once is sufficient to perform its task, you do not need to press it twice as with the 6150AD3/4/5/6.
- **Speaker Key:**
This key switches acoustic alarms off. If there is no acoustic alarm, and the instrument indicates dose rate, the key turns the acoustic single pulse detection on and off. The key performs additional tasks within functions that have been called with the function key (see explanation of function key below).

- **Illumination Key:**

This key switches the back-light on and off. This is different from the 6150AD, where the corresponding key always switches on, and the illumination automatically goes out after 10 seconds.

- **Function Key:**

This key successively calls the following functions (contrary to the 6150AD, keeping this key depressed will not return to dose rate indication):

- **Dose rate mean value and standard deviation:**

This function displays dose rate mean value. Pressing the on/off key once clears the mean value and starts measurement of a new mean value. Pressing the speaker key toggles indication between mean value (for example, 0.20 $\mu\text{Sv/h}$) and its standard deviation (for example, 4.5%).

- **Dose rate alarm threshold:**

This function displays the current dose rate alarm threshold digitally with the speaker symbol in the upper left corner. By pressing the speaker key successively, you may select a different threshold from this set of fixed values:

250 $\mu\text{Sv/h}$,
1.0 mSv/h ,
2.5 mSv/h ,
10.0 mSv/h ,
25.0 mSv/h ,
OFF (dose rate warning disabled).

This threshold works as follows: if dose rate reaches or exceeds the threshold, the Teletector automatically switches to dose rate indication and issues an intermittent sound as an acoustic warning. As a visual warning, the speaker symbol flashes. You may switch off the acoustic alarm with the speaker key.

- **Dose rate maximum value:**

This function displays »MAX« and the maximum dose rate that was measured since the instrument was switched on or since the maximum value was reset to zero. Pressing the on/off key once clears the maximum value and starts measurement of a new maximum value.

- **Dose:**

This function displays the dose that was accumulated since the instrument was switched on or since the dose was reset to zero. Pressing the on/off key once clears the dose.

- **Dose alarm threshold:**

A 6150AD with telescopic probe 6150AD-t does not have a dose alarm threshold. To keep operation of both instrument types as similar as possible, the Teletector 6112M now also does not have a dose alarm threshold. It just displays the speaker symbol and »OFF«.

- **Battery voltage:**

This function displays the battery voltage digitally with the battery symbol in the upper right corner.

- **Return to dose rate indication:**

Pressing the function key once more returns to dose rate indication. Before returning to dose rate indication, the 6150AD would display its calibration parameters. The

Teletector skips this indication because it uses different types of calibration parameters that cannot be compared with the 6150AD's ones.

6.3 Fire Brigade Mode

This mode is intended for less experienced users like, for example, fire brigades. Operation is very simple. The only threshold is a dose rate alarm threshold fixed at $25\mu\text{Sv/h}$. The Teletector only indicates dose rate as follows:

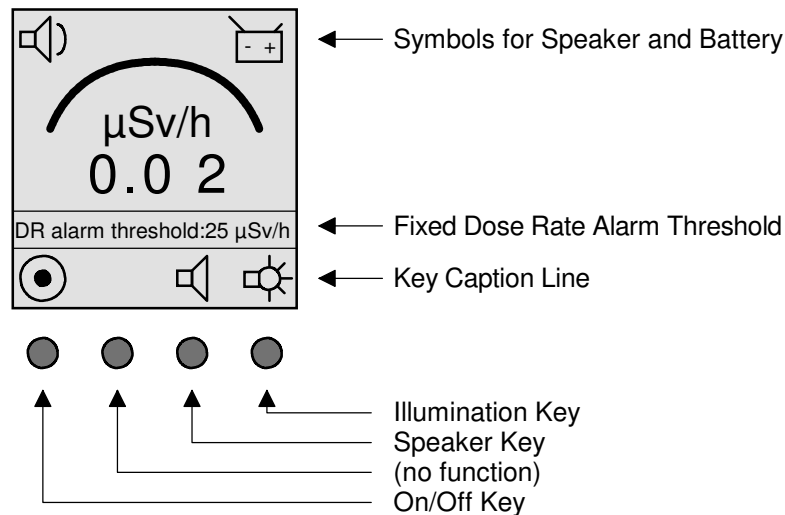

The speaker symbol indicates whether the speaker is on. A flashing speaker symbol indicates dose rate alarm.

The battery symbol flashes at battery voltages below 4 volts, otherwise it is invisible.

- **On/Off Key:**
This key switches the instrument on and off.
- **Speaker Key:**
This key switches the speaker on and off. The key switches off any acoustical signal, including a warning. Pressing the key again switches the acoustical signal on again, including a warning. This means that the key does not cancel acoustical alarms, but acts just like a simple on/off switch. While the speaker is on, it emits one of these sounds:
 - acoustic single pulse detection,
 - intermittent sound in case of dose rate alarm,
 - continuous sound in case of battery alarm.
- **Illumination Key:**
This key switches the back-light on and off.

7. Telescope

The stainless steel telescope extends continuously up to a total length of approx. 4 m. You may use it at any length without the need to arrest its segments. A cable inside the telescope connects the tube housing at the telescope's tip with the electronics in the Teletector's housing. A coil spring rolls up the cable automatically. To protect this mechanism, avoid pulling out or pushing together the telescope too rapidly. With the telescope completely pushed together and the protection cap applied, the Teletector meets protection class IP 67.

8. Detecting Beta Radiation

Only the low range tube can detect beta radiation. The status line must indicate the down arrow corresponding to the low range tube. This is always the case at gamma dose rates below 7 mSv/h. In the range of 7 mSv/h to 10 mSv/h the high range tube may be active. Above 10 mSv/h the high range tube is always active making detection of beta radiation impossible.

To detect beta radiation you have first to measure gamma dose rate with the protection cap put on (the protection cap will prevent beta radiation from entering the detector). If indication increases when removing the cap, additional beta radiation exists. It depends on the energy of the beta radiation how strong the cap will reject it. The rejection ratio is about 100 (see table below).

The Teletector indicates beta radiation in Sv/h just like it does with gamma radiation, because its electronics cannot distinguish between beta and gamma radiation. The Teletector applies the Cs-137 calibration factor to all pulses coming from the tube, even if the pulses' origin is beta radiation. Therefore dose rate indication caused by beta radiation is not the true beta dose rate, it only tells you that beta radiation exists.

NOTE! You can detect beta radiation, but you cannot really measure it! The indication in Sv/h is not the true beta dose rate!

The table below (data measured by PTB) shows response for various radiation qualities referred to Directional Dose Equivalent (Rate) $H'(0.07)$. Direction of radiation incidence is parallel to the Teletector's axis, that is perpendicular onto the end window.

Response referred to $H'(0.07, 0^\circ)$

Radiation Quality	Mean Beta Energy [keV]	Response referred to $H'(0.07, 0^\circ)$	Uncertainty	Remarks
Pm-147	60	0.035 (3.5%)	3%	Without Protective Cap
Pm-147	60	0.00024 (0.024%)	4%	With Protective Cap
Kr-85	240	0.044 (4.4%)	3%	Without Protective Cap
Kr-85	240	0.00023 (0.023%)	3%	With Protective Cap
Sr-90/Y-90	800	0.22 (22%)	2%	Without Protective Cap
Sr-90/Y-90	800	0.0031 (0.31%)	3%	With Protective Cap

A rough conclusion from the table and the data shown therein is: Without protective cap, the Teletector indicates some to several percent of the »true« beta dose (rate), whereas with the protective cap applied the indication is (far) below one percent of the true value.

9. Replacing the Batteries / Battery Warning

Four batteries (C cells, 1.5 V, IEC LR14) inside the handle supply the Teletector. A new set of alkaline batteries allows about 100 operating hours. LCD illumination will shorten battery life considerably.

If battery voltage drops below 4.5 volts, the Teletector operates illumination at approximately half power to save energy. Below 4.0 volts it switches illumination completely off and issues acoustic and visual warning. Whereas acoustic warning is always a continuous sound, visual warning depends on operation mode: in 6112M mode the function line alternates between »BATTERY CONDITION« and its normal text, in the other two modes the battery symbol in the upper right corner of the display flashes. In case of battery warning you should replace the batteries.

You have to screw off the Teletector's handle to replace the batteries. A rubber seal ring inside the handle prevents the batteries from slipping out of the handle. First remove that ring, then replace the batteries, then re-insert the ring, and finally screw the handle on again.

NOTE! **The »plus« end of the batteries must point towards the housing. Compared to the previous models Teletector 6112B and 6112D this is exactly reversed! For this reason the 6112M has a different handle which cannot be interchanged with the handle of the other two Teletector models!**

You should remove the batteries when not using the instrument for a prolonged period of time.

You may also operate the instrument with accumulators (rechargeable batteries). However, voltage of accumulators gives only poor information about their capacity, therefore battery warning will be much less reliable.

10. Serial Interface Connector

The serial interface connector is placed at the side of the Teletector's housing. Communication with a computer flows through this connector. Another application of this connector is to connect an earphone.

10.1 Pin Assignment

The socket's pins do not carry numbers. You have to identify the pins by their arrangement relative to the semicircle and the red marking:

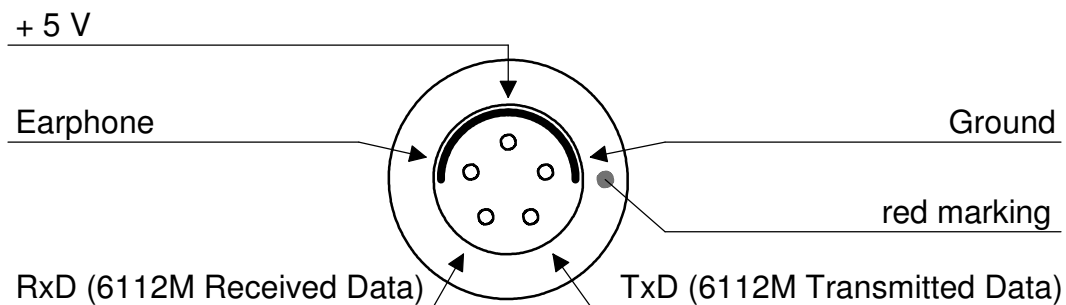

10.2 Serial Interface

The serial interface is bi-directional (RxD/TxD). The Teletector outputs dose rate through this interface at one-second intervals, which is the same cycle as for calculating dose rate. The output format is binary; section 13.5 explains this format in detail. To connect the Teletector to a PC, the connecting cable type 865.1.3 is available as an optional accessory.

With suitable software you may also load your customized places or read their recordings through this interface.

10.3 Earphone Output

The earphone type 865.1.4 (optional accessory) also plugs into this connector. Acoustic signals transmitted to the earphone are the same as for the built-in speaker. However, the earphone is always on, even if the speaker was switched off by the speaker key.

10.4 Power Supply

Pins »Ground« and »+5V« make the Teletector's regulated internal supply available at the connector. Maximum external load for this output is 100 mA.

11. Energy Dependence and Directional Dependence

The following radiation sources were used to obtain the data presented in this section:

- Cs-137 (662 keV),
- Co-60 (mean energy 1250 keV),
- filtered X radiation according to the N series (»Narrow spectrum«) from ISO 4037-1.

The diagrams show typical curves, in practice slight deviations are normal and cannot be avoided.

All energy curves are normalized to the indication at Cs-137. Directional dependencies of the H_x model 6112M are normalized to the indication in preferential direction at the same energy. Directional dependencies of the $H^*(10)$ model 6112M/H are normalized to the indication in preferential direction at Cs-137. The reason for the different normalization of directional dependencies is that the change from H_x to $H^*(10)$ was accompanied by a change of official requirements:

- For H_x models, the energy dependence in preferential direction was required not to deviate by more than $\pm 30\%$ referred to Cs-137. The directional dependence within a cone of $\pm 45^\circ$ around the preferential direction was required not to deviate by more than $\pm 20\%$ referred to the same energy in preferential direction. This means that requirements for energy dependence and directional dependence were completely independent of each other. There was no consideration for the fact that deviations caused by energy and direction may compensate or add.
- For $H^*(10)$ models, there is no separate but a combined requirement for energy and directional dependence. It says that, for all energies and all directions within a cone of $\pm 45^\circ$ around the preferential direction, the error must not exceed $\pm 40\%$ referred to indication at Cs-137 in preferential direction. The new requirement has little to do with the new quantity $H^*(10)$ itself; it was introduced together with $H^*(10)$ merely because it was regarded to be more realistic.

The range meeting the requirements is called »nominal energy range«. When using the instrument you have to observe that energy is within that range. In other words, you need to know something about the radiation to be measured:

- If radiation energy is considerably lower than the beginning of the nominal energy range, the instrument's response will decrease considerably even down to »blindness«. You will then underestimate the radiation field. This may particularly happen with low energy X radiation.
- It depends on the type of instrument how it responds to energies above the end of the nominal energy range. A common question is how an instrument will respond to the 6 MeV radiation of N-16 that occurs in a nuclear facility. It is well-known that energy compensated GM tubes as used in the 6112M will always overrespond at such high energies (up to three times the true value). Therefore, although the 6112M is not suited to measure such a high energy radiation field correctly, it will overestimate the radiation and thus the radiation risk. In terms of radiation protection, it will be more strict than it has to be.

11.1 6112M

Energy dependence referred to H_x , normalized to Cs-137:

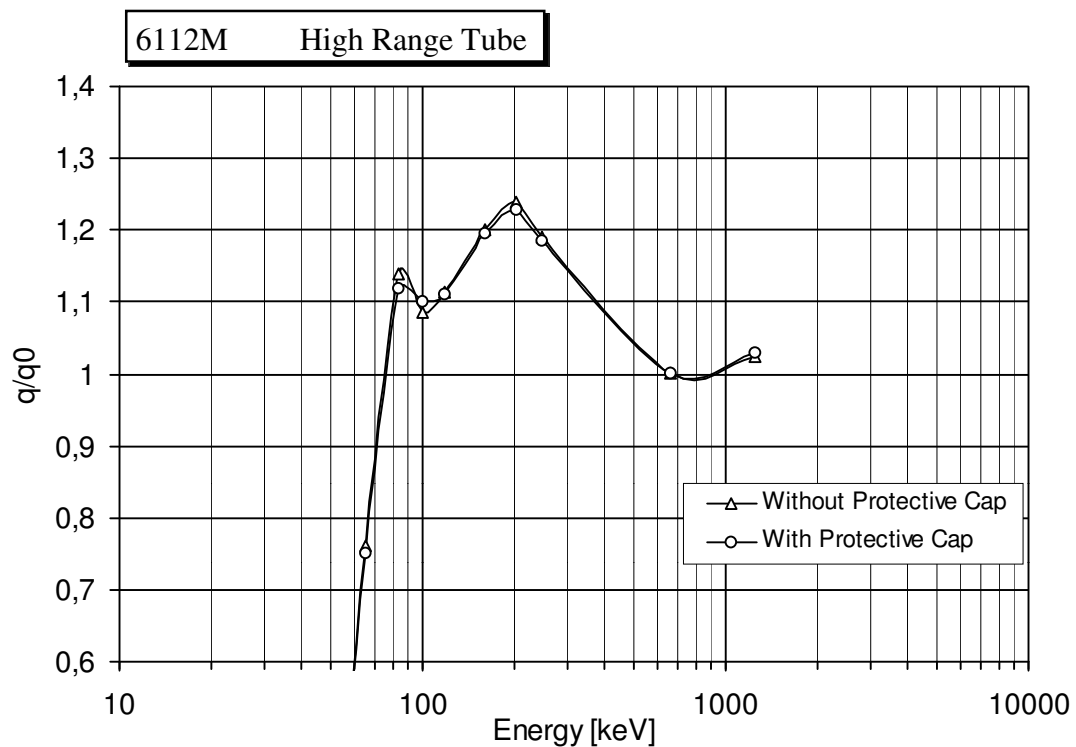
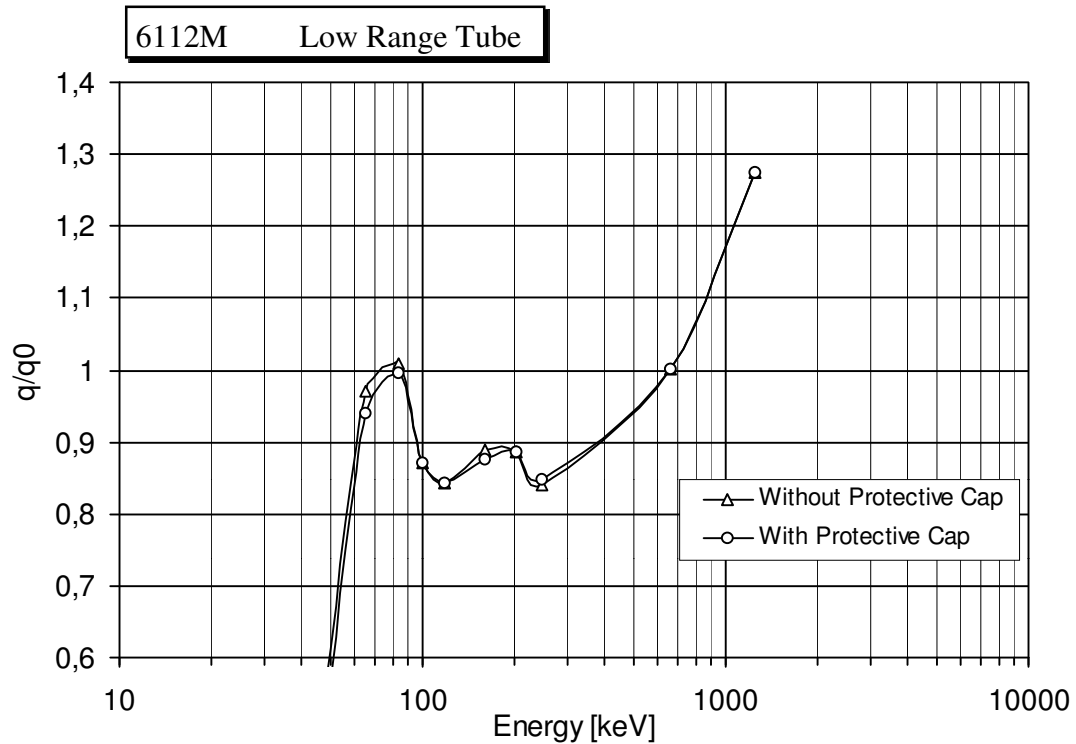

Directional dependence (rotation perpendicular to the axis) at N-100 (mean energy 83 keV) normalized to indication at the same energy in preferential direction. The error shall not exceed $\pm 20\%$ down to energies 20 keV above the beginning of the nominal energy range:

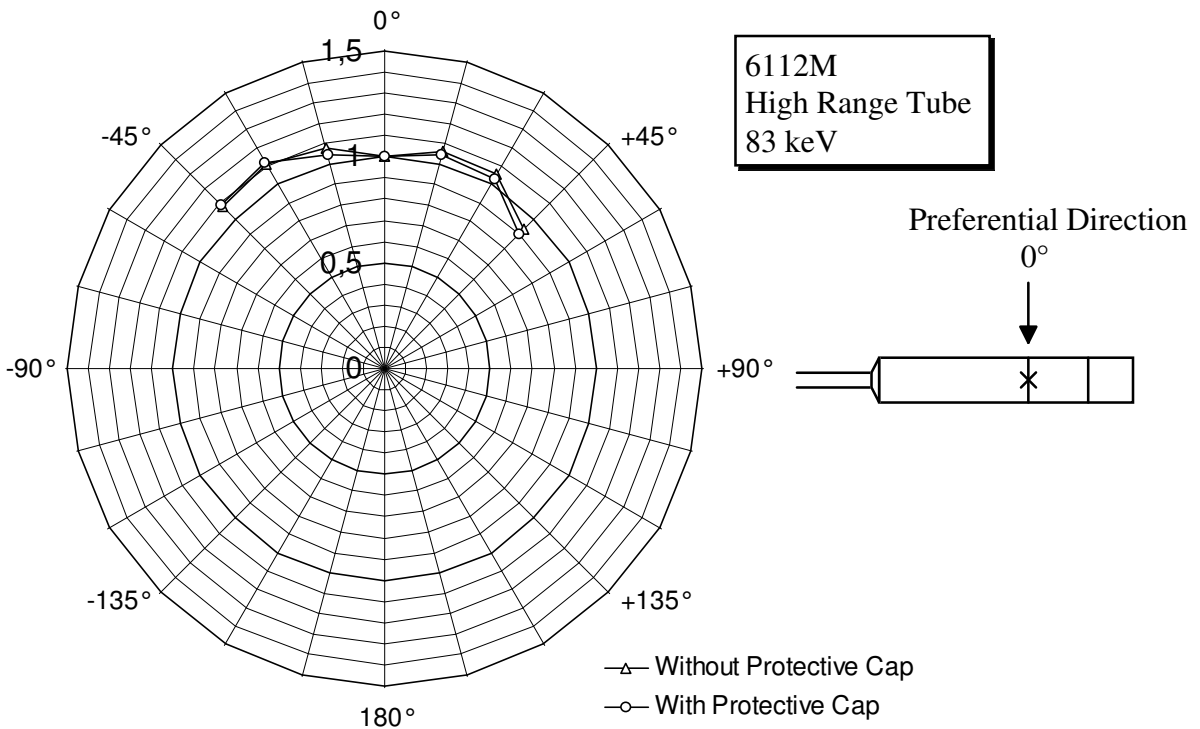
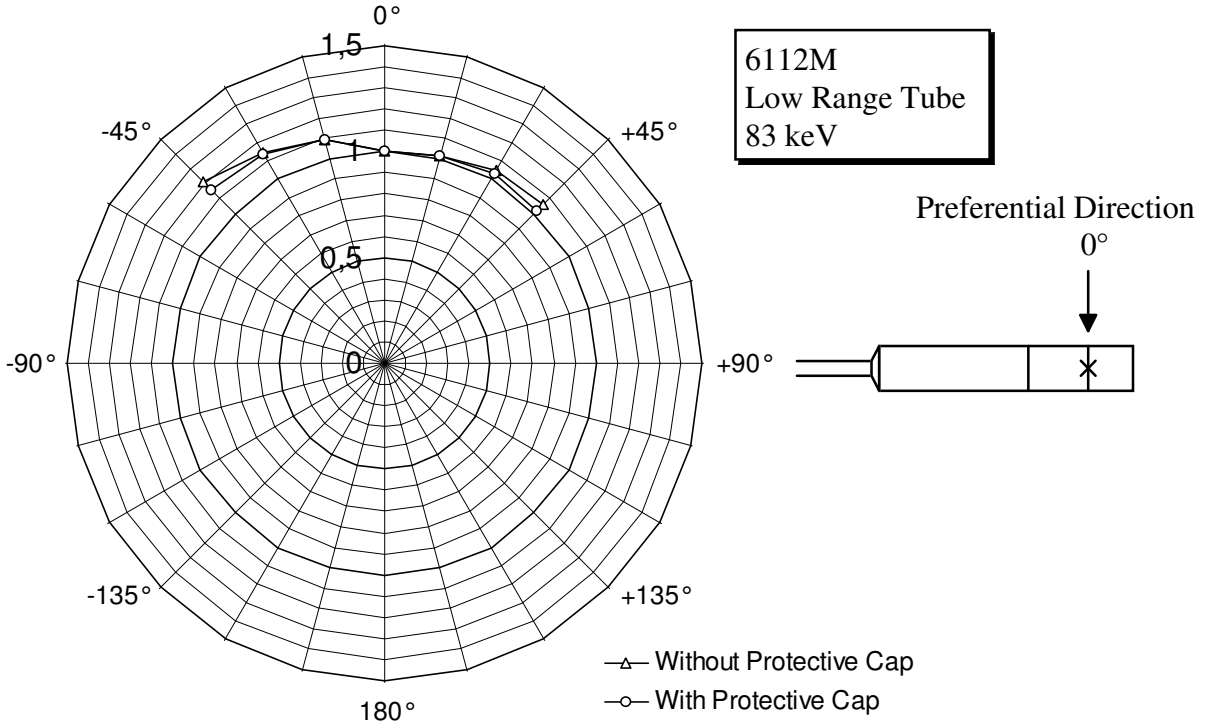

11.2 6112M/H

Energy dependence referred to $H^*(10)$, normalized to Cs-137:

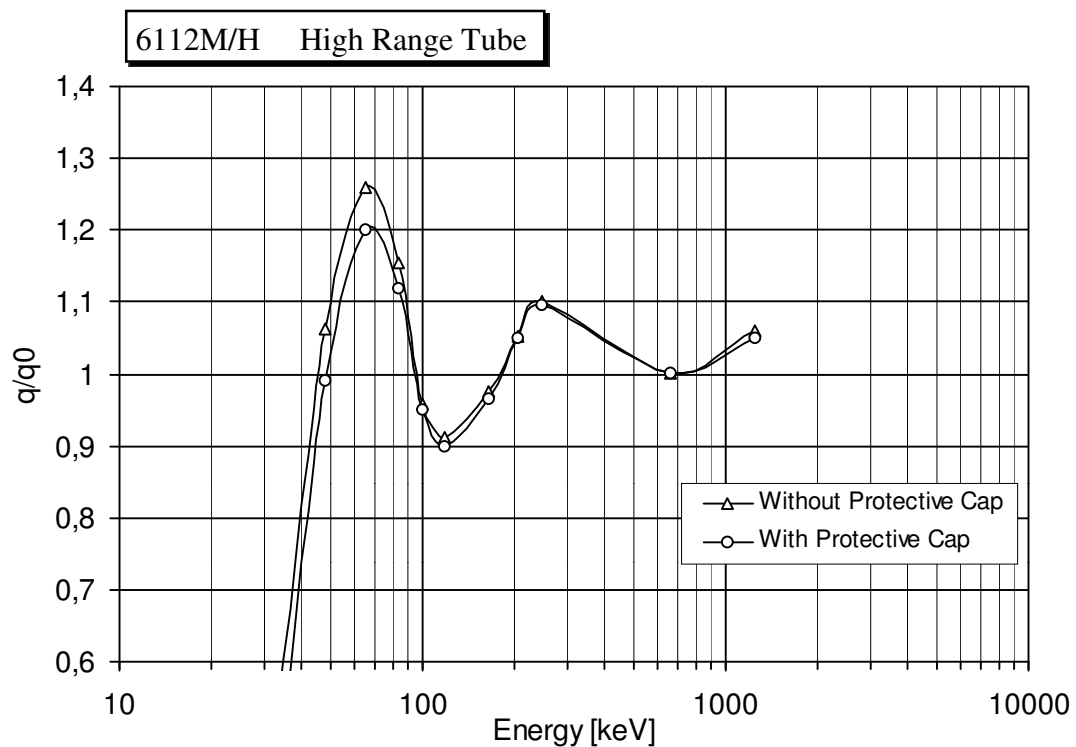
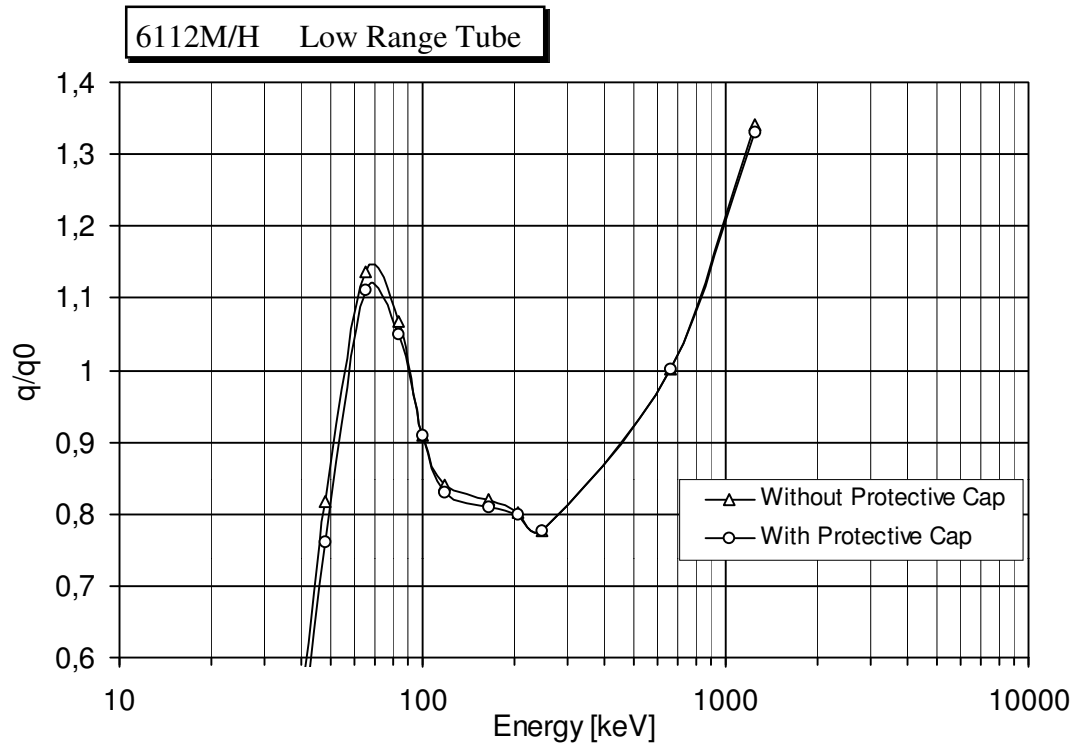

Directional dependence referred to $H^*(10)$ (rotation perpendicular to the axis) at N-60 (mean energy 47,9 keV) normalized to indication at Cs-137 in preferential direction. The error shall not exceed $\pm 40\%$ for all energies and directions within their nominal ranges:

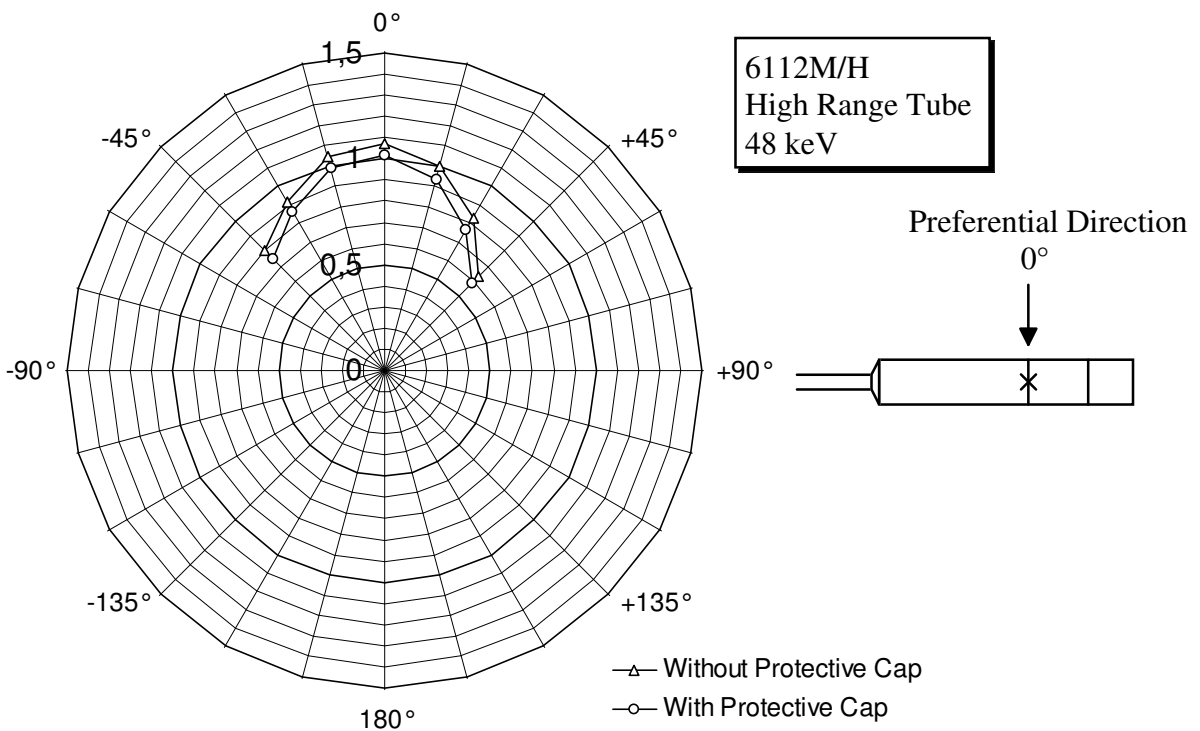
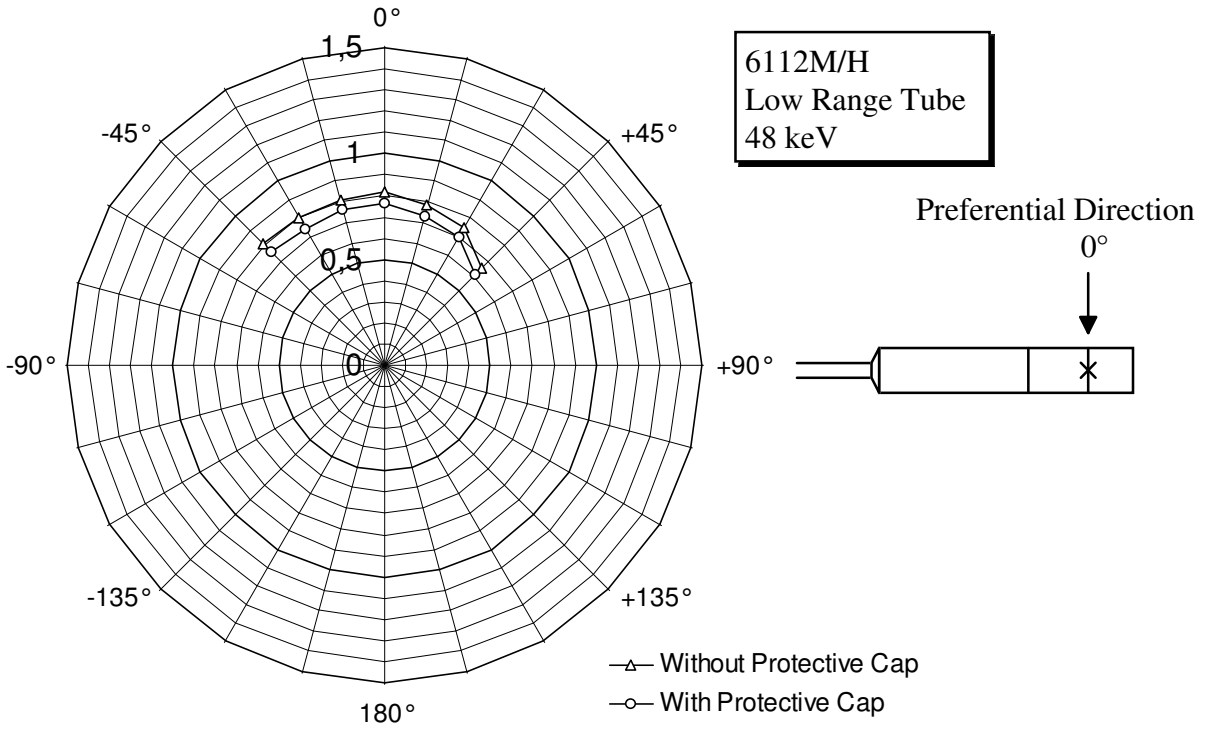

12. Radiological Check

You will need the following optional accessories for a radiological check:

- Check source 6706 (nominal activity 333 kBq Cs-137) or equivalent source according to DIN 44427,
- Source holder 761.14.

This equipment allows to expose either of the two tubes to a well-defined dose rate. In the following we shall call the indication obtained under these conditions a »check reading«. There is a check reading for each of the tubes. The absolute value of the check reading already gives some information on measuring accuracy. However, the absolute value contains uncertainties like the $\pm 10\%$ tolerance of source activity. But, if you always use the same source and holder for repeated check readings, the check readings will not vary by more than a standard deviation of 4%. Consequently, the most accurate method is: use the first check reading as a reference, compare further check readings with this reference, and observe to use always the same source and holder. This method will quickly reveal changes in the Teletector's accuracy, because it restricts errors to statistical errors and avoids systematic errors like activity tolerance. Of course you should carry out the reference measurement at a time when you know that the instrument is properly calibrated, for example directly after purchasing it.

Follow this procedure to obtain a check reading:

First make sure that the Teletector is in 6112M operation mode. Put the holder 761.14 onto the tube housing until it stops and arrest it with the screw. Screw the check source into the place for the low range tube (marked on the holder as NDL) or for the high range tube (marked as HDL) until it stops. Select menu option SERVICE / CHECK DETECTORS and select the tube that is exposed to the source. Start measurement by pressing »STAR«; the key's caption changes to »STOP«. You may stop the measurement by pressing this key again. However, we recommend not to stop the measurement, but to wait until the Teletector automatically stops the measurement because 10 000 pulses were collected. The automatic stop at 10 000 pulses ensures a standard deviation of 1%, which means sufficient statistical accuracy. The value displayed after the measurement is the check reading.

The duration of the measurement depends on age (activity) of the check source, and on the tube involved. With a new source the high range tube needs about 1.5 hours to collect 10 000 pulses, whereas the low range tube only needs about 1.2 minutes.

With a new source the check readings will be approximately:

- Low range tube: 6112M: 90 μ Sv/h, 6112M/H: 95 μ Sv/h
- High range tube: 6112M: 42 μ Sv/h, 6112M/H: 45 μ Sv/h

NOTE! The check readings just specified are typical values only. They may vary slightly from one Teletector to the other, and they are affected with the uncertainty of check source activity. Therefore these values are for your guidance only, they must not be used for adjusting calibration!

When comparing two check readings performed at different dates, you have to consider the activity loss of the check source. This is done by multiplying the check reading »R« with a correction factor »c«. The result is the »corrected check reading Rc«. You may only compare check readings corrected to the same reference date. As reference date you may take the date when the source had its nominal activity (usually printed on the source), or the date when the reference measurement was performed. In the latter case, the age of the source is irrelevant. The correction factor c depends on the half-life of the check source (30 years in the case of Cs-137) and the period of time you want to correct for. For Cs-137, you can take the correction factor c as a function of time from the table below.

Example (correction for the age of the check source):

age of check source: 5 years => correction factor c = 1.122 (see table below)
 check reading R: 38 µSv/h
 corrected check reading Rc : 38 µSv/h • 1.122 = 42.64 µSv/h

Correction Factor c for Cs-137 (half-life 30.0 years)
t is the period of time (in years) since the reference date

t / years	c	t / years	c	t / years	c
0.0	1.000				
0.5	1.012	10.5	1.275	20.5	1.606
1.0	1.023	11.0	1.289	21.0	1.625
1.5	1.035	11.5	1.304	21.5	1.643
2.0	1.047	12.0	1.320	22.0	1.662
2.5	1.059	12.5	1.335	22.5	1.682
3.0	1.072	13.0	1.350	23.0	1.701
3.5	1.084	13.5	1.366	23.5	1.721
4.0	1.097	14.0	1.382	24.0	1.741
4.5	1.110	14.5	1.398	24.5	1.761
5.0	1.122	15.0	1.414	25.0	1.782
5.5	1.136	15.5	1.431	25.5	1.803
6.0	1.149	16.0	1.447	26.0	1.823
6.5	1.162	16.5	1.464	26.5	1.845
7.0	1.176	17.0	1.481	27.0	1.866
7.5	1.189	17.5	1.498	27.5	1.888
8.0	1.203	18.0	1.516	28.0	1.910
8.5	1.217	18.5	1.533	28.5	1.932
9.0	1.231	19.0	1.551	29.0	1.954
9.5	1.245	19.5	1.569	29.5	1.977
10.0	1.260	20.0	1.587	30.0	2.000

13. Technical Data

13.1 Teletector 6112M

Note: specifications marked ^(PTB) are PTB approved.

	6112M	6112M/H
Detectors: a) low range tube b) high range tube	<p>beta gamma end window tube ZP1400, energy compensated, effective length 40 mm, sensitivity at Cs-137 approx. 5800 pulses per μSv</p> <p>gamma tube ZP1300, energy compensated, effective length 8 mm, sensitivity at Cs-137 approx. 100 pulses per μSv</p>	
Switching detectors	<p>automatically with hysteresis: switches up to high range when dose rate goes above 10 mSv/h, and switches back to low range when dose rate goes below 7 mSv/h; manual selection of detector for radiological check.</p>	
Measuring quantity: photon or ambient dose equivalent (rate), respectively	H_X, \dot{H}_X	$H^*(10), \dot{H}^*(10)$
Dose rate range	<p>analog: ZP1400: 0.1 $\mu\text{Sv/h}$ to 10 mSv/h ZP1300: 7 mSv/h to 10 Sv/h digital: 0.01 $\mu\text{Sv/h}$ to 10 Sv/h</p>	
Instrumental background	< 20 nSv/h (low range tube)	
Linearity of dose rate measurement	$\pm 8\%$ within nominal energy range ^(PTB) (permitted: $\pm 10\%$) (calibration with Cs-137)	
Dose range	10 nSv to 10 Sv (beyond 10 Sv up to 100 Sv flashing)	
Alarm thresholds	adjustable threshold for both dose and dose rate	
Detection of beta radiation	with end window tube ZP1400 through window in the face of the tube housing. Protective cap must be removed. Protective cap rejection factor: in the order of 100.	
Thickness of beta window	<p>tube window: 2 - 3 mg/cm² protective foil: 6 mg/cm² sensitive area: approx. 60 mm²</p>	
Energy dependence (protective cap applied or removed): nominal range change of response referred to Cs-137	<p>65 keV to 1.3 MeV ^(PTB)</p> <p>$\pm 30\%$ ^(PTB) (permitted: $\pm 30\%$)</p>	<p>45 keV to 1.3 MeV ^(PTB)</p>

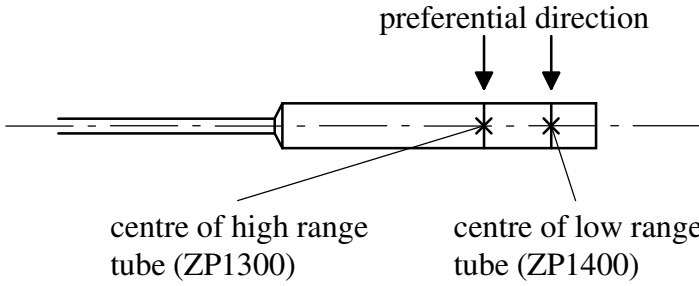
	6112M	6112M/H
Directional dependence (protective cap applied or removed): nominal range	$\pm 45^\circ$ around preferential direction ^(PTB)	$\pm 45^\circ$ around preferential direction ^(PTB)
change of response referred to preferential direction at the same energy	$\pm 16\%$ ^(PTB) (permitted: $\pm 20\%$)	
Directional and energy dependence for all energies and directions within their nominal ranges referred to Cs-137 at preferential direction (protective cap applied or removed)		$\pm 40\%$ ^(PTB) (permitted: $\pm 40\%$)
Preferential direction and location of detectors	Preferential direction: radial on marking grooves on the tube housing: 	
Display	fully graphic LCD (128 x 128 pixels) transflective, LED back-light	
Range selection	automatically	
Dose rate warning	acoustically and visually	
Overload	dose rates above the full range (10 Sv/h) are indicated as over-range up to dose rates of 100 Sv/h; after overload the Teletector is still functioning ^(PTB)	
Detection of single pulses	acoustically, speaker may be replaced for decontamination	
Speaker loudness level	> 90 dBa in a 30 cm distance	
Climatic conditions	temperature range: -20°C to $+60^\circ\text{C}$ humidity: nominal range up to 95% (at -20°C to $+60^\circ\text{C}$) change of response: $\pm 6\%$ ^(PTB) (permitted: $\pm 10\%$)	
Storage temperature	-40°C to $+85^\circ\text{C}$	
Atmospheric pressure	nominal range: 60 to 130 kPa (600 to 1300 mbar)	
Geotropism (change of response as a result of gravitational effects)	none	
Teletector housing	aluminium die-cast	
Telescope	stainless steel	
Protection class	IP 67 according to DIN 40050 if telescope completely pushed together and protective cap applied	

	6112M	6112M/H
Supply voltage range and power supply	4.0 to 7.0 Volt four C cells (LR14, AM2)	
Battery life	approx. 100 hours with alkaline batteries (without illumination and speaker)	
Dimensions	length 970 mm (telescope pushed together) 4170 mm (telescope pulled out) width 130 mm max. height approx. 90 mm	
Weight	2.7 kg (without batteries) 3.0 kg (including batteries)	
CE compatible according to	EN 50 082-2:1995, EN 55 011:1998, ENV 50 140:1993, EN 61 000-4-2:1995	
PTB approval	<div style="border: 1px solid black; padding: 2px; display: inline-block;">23.01</div> <div style="border: 1px solid black; padding: 2px; display: inline-block;">00.01</div> Note: This approval applies to the German version which uses the same hardware but has some software restrictions: the unit (Sv, R, Gy) cannot be selected, it is fixed at Sv; the time constant cannot be selected, its range is fixed at 16s-2s.	<div style="border: 1px solid black; padding: 2px; display: inline-block;">23.51</div> <div style="border: 1px solid black; padding: 2px; display: inline-block;">03.02</div> Note: This approval applies to the German version which uses the same hardware but has a software restriction that fixes the time constant to the range of 16s-2s.

13.2 Earphone 865.1.4

Type	dynamic earphone with earclip, 500 ohms
Dimensions	diameter without earclip 21 mm, thickness 12 mm
Cable length	1.5 m

13.3 Connecting Cable 865.1.3

Application	connects the Teletector 6112M to the serial interface of a PC
Length	3 m
Connector at PC end	female 9 pin D-sub that plugs into a PC's standard COM port
Connector at Teletector end	5 pin waterproof connector that plugs into the Teletector's serial interface

13.4 Source Holder 761.14

Application	holder to mount check source 6706 onto the tube housing
Length	88 mm
Diameter at »HDL« position Diameter at »NDL« position	86 mm 56 mm The diameters are large enough to compensate deviations from the Teletector's rotational symmetry. Check readings will only vary slightly when turning the holder around its axis. Including any rotational position around the axis, check readings can be reproduced with a standard deviation not exceeding 4% (including the 1% statistical uncertainty for a pulse count of 10 000).
Material	grey plastic
PTB approval	<div style="border: 1px solid black; padding: 2px; display: inline-block;">23.11</div> <div style="border: 1px solid black; padding: 2px; display: inline-block;">00.02</div>

13.5 Serial Interface

This section addresses to users who would like to read and process the dose rate the Teletector transmits at one-second intervals. For this purpose we shall explain data format in detail.

First please note that the interface's electrical properties (voltage levels) do not exactly meet RS232 specification:

	Teletector output	RS232 output	RS232 input
logical 0 (»space«)	+5V	+5...+15V	> +3V
logical 1 (»mark«)	GND	-5...-15V	< -3V

This means the Teletector does not output the logical 1 as a negative voltage, but as ground level. RS232 does not define levels in the range of -3V to +3V, which means it is up to the receiver whether it reads ground level as a logical 0 or 1. However, in practice all PCs read ground level like the negative level, that is as the logical 1. For this reason we decided not to generate a negative voltage for the interface only, which would have meant useless extra effort. Apart from extremely rare exceptions, the Teletector's non-standard ground level will not cause any problems.

Interface parameters are as follows:

4800 baud, 8 data bits, no parity, 1 start bit, 1 stop bit.

There is no handshaking. For example, if you would like to read the data with a BASIC program through a PC's COM1, use this statement to open the interface:

OPEN "com1:4800,n,8,1,rs,cs,ds,cd" FOR INPUT AS #1

Format of the transmitted data is binary, which means the data have to be decoded before they can be displayed on the screen. Once per second the Teletector transmits the following string of six bytes (remark: this is exactly the same string a 6150AD6 with a telescopic probe 6150AD-t would transmit):

1. STX (»start of text«, binary 2) as start character
2. detector in use and 6112M model (measuring quantity):
 - 6112M: binary 21 for low range tube, binary 22 for high range tube
 - 6112M/H: binary 149 for low range tube, binary 150 for high range tube
3. MLO mantissa of dose rate (low byte)
4. MHI mantissa of dose rate (high byte)
5. EXP exponent of dose rate
6. check sum.

The check sum (last byte) is the XOR (eXclusive OR) of bytes 2 through 5 and serves to detect transmission errors. If the receiver (PC) recognizes a transmission error because the check sum does not fit the preceding bytes, it has to discard the string and wait for the next one. There is no way to ask the Teletector for a repetition of the last string.

Bytes 3 through 5 contain the current dose rate in $\mu\text{Sv/h}$ as a floating point number. The unit is always $\mu\text{Sv/h}$, even if the 6112M model's indication was set to a different unit (R/h or Gy/h). Dose rate consists of a signed 8-bit exponent on the base of 2 (exponent range -128 to +127) and an unsigned (positive) 16-bit mantissa (range 4000H to 7FFFH, 0000H for zero) with the weight of 2^{-15} . The following BASIC program fragment shows how to convert the three bytes MLO, MHI, and EXP to dose rate DR (in $\mu\text{Sv/h}$):

```
IF EXP > 127 THEN EXP = EXP - 256
MANT = MHI * 256 + MLO
DR = MANT * 2^(EXP - 15)
```

◆